

CPDQ4V5MASB-HF

RoHS Device

Halogen Free



Features

- ESD protection for one line with Bi-directional.
- Protect one I/O line or one power line.
- Fast turn-on and low clamping voltage.
- IEC 61000-4-2 (ESD) ± 30 kV (air/contact)
- IEC 61000-4-4 (EFT) 80A (5/50ns)
- IEC 61000-4-5 (Lightning) 60A (8/20 μ s)

Mechanical data

- Case: DFN1006-2L package, molded plastic.
- Mounting position: Any.

Circuit Diagram

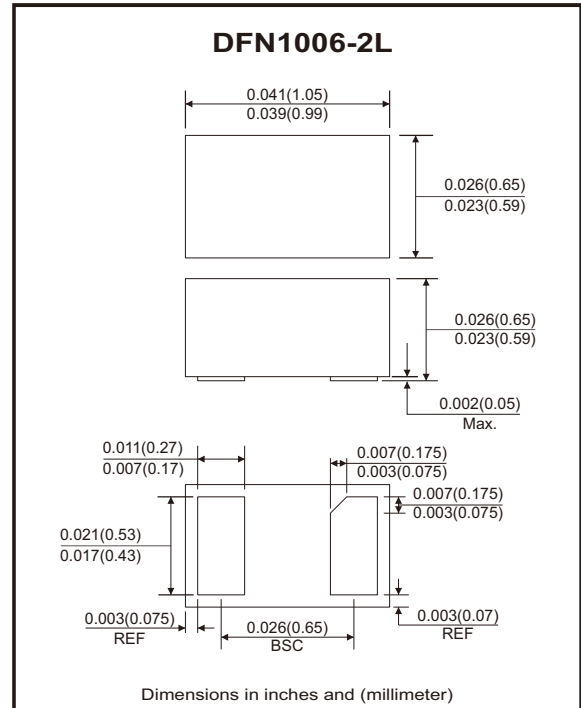

Maximum Rating (at TA=25°C unless otherwise noted)

Parameter	Conditions	Symbol	Value	Unit
Peak pulse power	T _P = 8/20 μ s	P _{PP}	660	W
Peak pulse current	T _P = 8/20 μ s	I _{PP}	60	A
ESD capability	IEC 61000-4-2(air) IEC 61000-4-2(contact)	ESD	± 30	kV
Operating temperature range		T _J	-55 to +125	°C
Storage temperature range		T _{STG}	-55 to +150	°C

Electrical Characteristics (at TA=25°C unless otherwise noted)

Parameter	Conditions	Symbol	Min	Typ	Max	Unit
Working peak reverse voltage		V _{RWM}			4.5	V
Reverse leakage current	V _{RWM} = 4.5V	I _R			100	nA
Breakdown voltage	I _T = 1mA	V _{BR}	4.7		8.0	V
Clamping voltage	I _{PP} = 10A, T _P = 8/20 μ s	V _C		6		V
Clamping voltage	I _{PP} = 60A, T _P = 8/20 μ s	V _C		9	11	V
Clamping voltage	TLP = 16A, T _P = 0.2/100ns	V _C		6.5		V
Junction capacitance	V _R = 0V, f = 1MHz	C _J		120		pF

Typical Rating and Characteristic Curves (CPDQ4V5MASB-HF)

Fig.1 - 8/20 μ s Peak Pulse Current Waveform Acc. IEC 61000-4-5

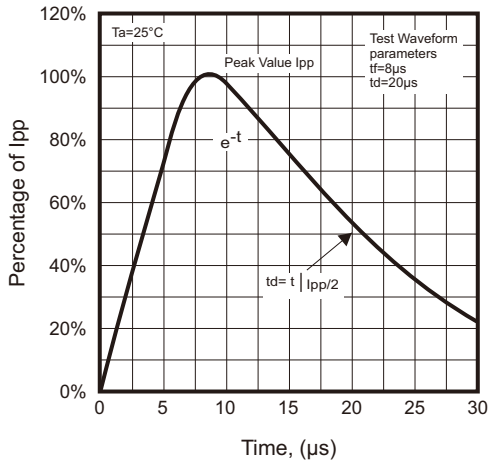

Fig.2 - Power Rating Derating Curve

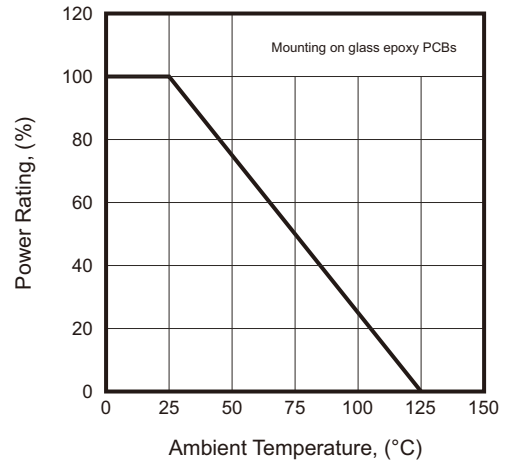

Fig.3 - Typical Clamping Voltage vs. Peak Pulse Current

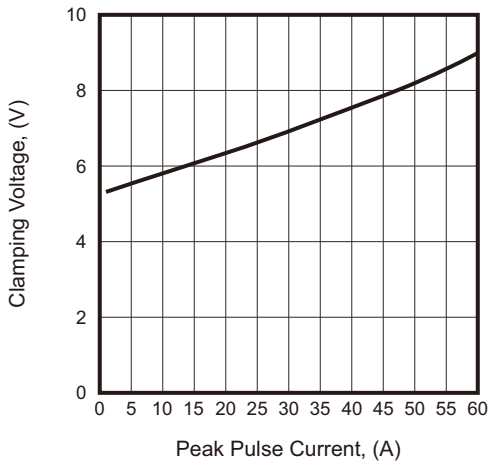

Fig.4 - Typical Capacitance Between Terminals Characteristics

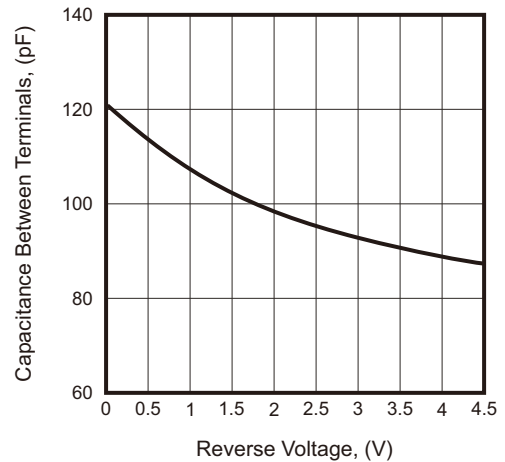

Fig.5 - TLP- Positive Pulse

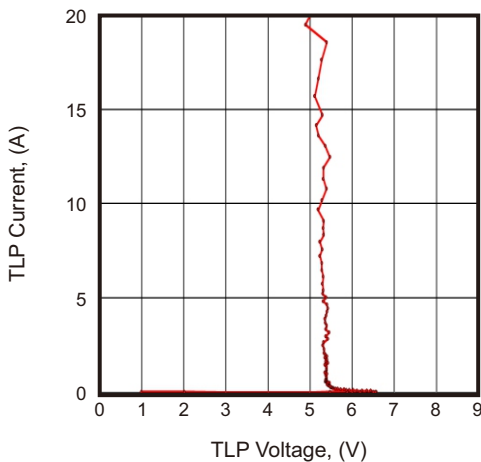
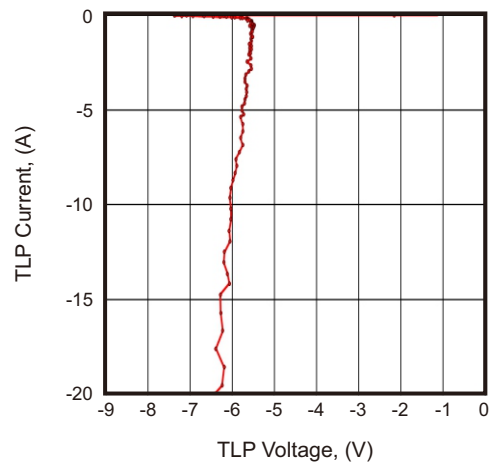
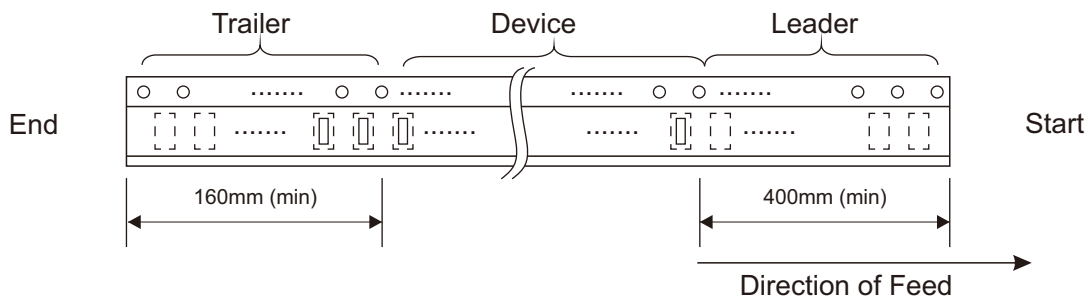
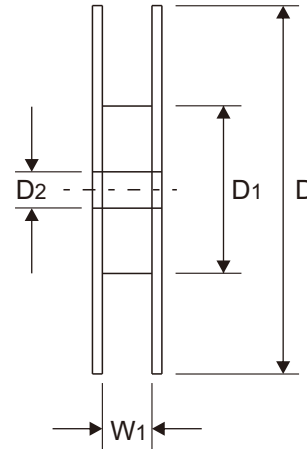
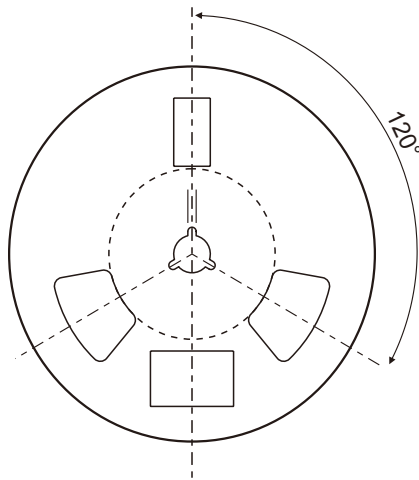
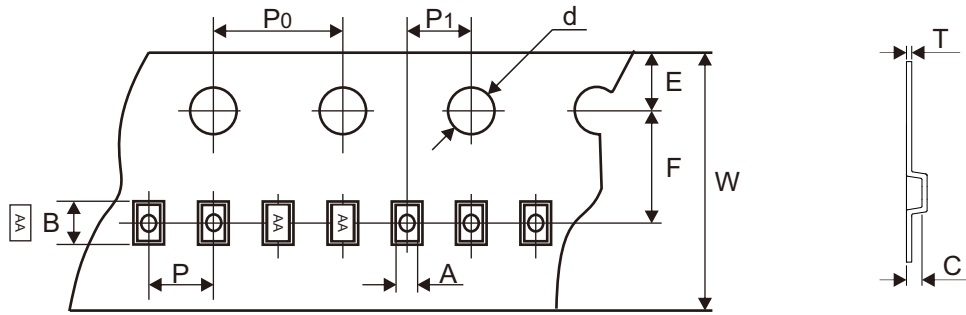

Fig.6 - TLP- Negative Pulse



Reel Taping Specification



DFN1006 -2L	SYMBOL	A	B	C	d	D	D1	D2
	(mm)	0.68 + 0.07 - 0.04	1.19 + 0.05 - 0.12	0.48 + 0.10 - 0.05	1.55 ± 0.05	181.00 Max	55.00 ± 5.00	13.00 + 0.50 - 0.20
	(inch)	0.027 + 0.003 - 0.002	0.047 + 0.002 - 0.005	0.019 + 0.004 - 0.002	0.061 ± 0.002	7.126 Max	2.165 ± 0.197	0.512 + 0.020 - 0.008

DFN1006 -2L	SYMBOL	E	F	P	P0	P1	T	W	W1
	(mm)	1.75 ± 0.10	3.50 ± 0.05	2.00 ± 0.10	4.00 ± 0.10	2.00 ± 0.05	0.21 ± 0.04	8.00 + 0.30 - 0.10	11.60 Max
	(inch)	0.069 ± 0.004	0.138 ± 0.002	0.079 ± 0.004	0.157 ± 0.004	0.079 ± 0.002	0.008 ± 0.002	0.315 + 0.012 - 0.004	0.457 Max

Marking Code

Part Number	Marking Code
CPDQ4V5MASB-HF	AA



Suggested P.C.B. PAD Layout

SIZE	DFN1006-2L	
	(mm)	(inch)
A	0.35	0.014
B	0.60	0.024
C	0.30	0.012
D	1.00	0.039

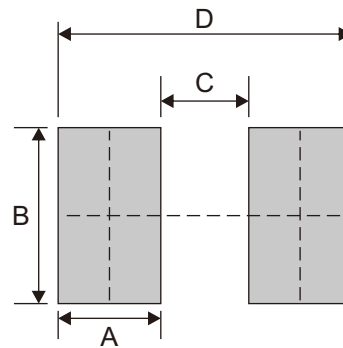

Standard Packaging

Case Type	REEL PACK	
	REEL (pcs)	Reel Size (inch)
DFN1006-2L	10,000	7